

PLEASE READ THE INSTRUCTIONS CAREFULLY BEFORE FITTING THE KIT.**If you have a problem, however small, call our Technical Department.**

Tel:- 01925 636950. Fax:- 01925 243111. Mon - Thurs 8.30 - 5pm.

1. Remove the three air box screws and remove the lid.
2. Remove the two hoses, green tab and white tab, **Drawing A**.
3. Using the screw supplied seal the end of the small red plastic pipe together with the plastic unit and attach to the other pipes, secure with the medium size plastic tie.
4. Remove the complete air filter box assembly including the flexi rubber hose attached behind the nearside headlight. Remove rubber gasket.
5. Remove the green plug from the green cold start sensor in the air box. Unscrew the sensor and refit the plug. Push the sensor and plug into the hole in the base of the filter (front section). **Drawing C & D**.
6. **Fitting the air filter. FOLLOW THE INSTRUCTIONS CAREFULLY.**
Make sure the filter neck and the intake flange are clean and free of oil. Fit the filter onto the flange, with the logo facing front and sensor in the middle hole. Hold the filter down and tighten the clip carefully until the filter will just turn on the flange, then one full turn 360 , No More.
7. **Cold Air System.**
Carefully expand the flexi air hose to approx. 42"/106cm.
 - 7.1. **Drawing E.** Remove the plastic screen next to the radiator. Cut out the section shown with a round cutter 2.25"/57mm. Alternatively cut out a square section 57mm x 57mm. Refit the plastic screen.
 - 7.2. **Carefully** elongate the end of the hose by tapping gently with the palm of the hand. **Don't press.**
 - 7.3. Feed the hose through the new hole from the engine side, turn down and then forward into the lower grille section **Drawing E**. Pierce a small hole in the ovalised hose and attach with a small plastic tie to the upright position.
 - 7.4. Continue hose towards the filter. Attach with plastic ties as **Drawing F**. The cold air should finish 4"/10cm from the filter, **No Nearer**. Point hose as **Drawing G**.
8. **Tuning.**
CAT. Cars. No adjustments are required.
An increase in fuel may be required if further engine modification are to be carried out.
9. **Filter maintenance.**
Under normal conditions clean and reoil the filter at approx. 40,000 miles/65,000 Km.
Use only K&N cleaner and oil and follow the instructions carefully.

K&N Filters are pre-oiled ready to fit.**The advantages of K&N's cold air intake system**

Cooler air being denser, will show positive improvements in power over filter systems that draw hot air from the engine bay.

This kit should contain:-

- 1 x Air Filter.
- 1 x Hose Clip size 100/120.
- 1 x Cold Air Hose Assembly.
- 1 x Instruction Sheet.
- 1 x Instruction Pack :-
 - 1 x Filter Maintenance Sheet.
 - 1 x K&N Window Sticker.
 - 1 x Million Mile Warranty Card.
 - 1 x Leaflet.
- 1 x Fixing Kit containing:-
 - 1 x Plastic Cable Tie (10cm Long).
 - 3 x Plastic Cable Tie (35cm Long)
 - 1 x Plastic Cable Tie (19cm Long).
 - 1 x M5 x 10 Pan Head Screw.

**IMPORTANT INSTRUCTIONS
FOR ROUND ENTRY
CLAMP ON AIR FILTERS**

Gently tighten the hose clip to the point where the filter will just rotate on the pipe or intake flange. Reposition the K&N logo straight, then **give the clip two turns i.e. 360 , no more.**

FITTING YOUR OWN 57i KIT

If not, **it is essential** that the person fitting the kit (e.g. mechanic) **carefully follows these particular instructions** even if he has fitted K&N kits before. This will save you both time and money. Kits incorrectly fitted may show a loss in performance e.g. the positioning of the essential cold air hose, (flexi expandable and rubber hoses are used).

A final check under the bonnet, by yourself, with the instructions, would seem sensible.

Drawing A

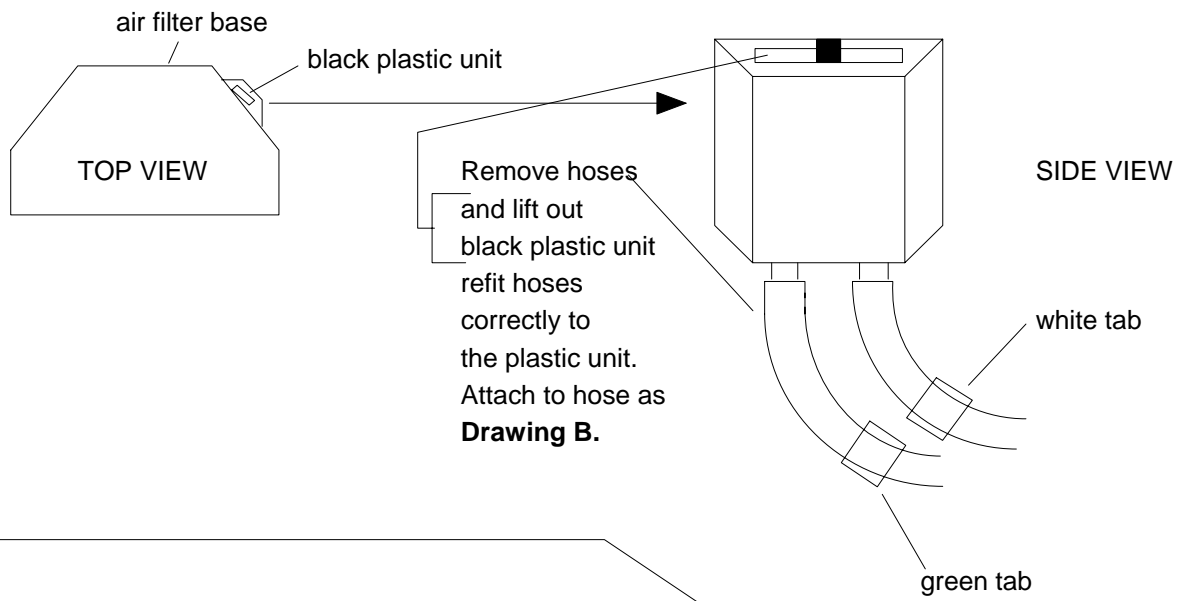

Drawing B

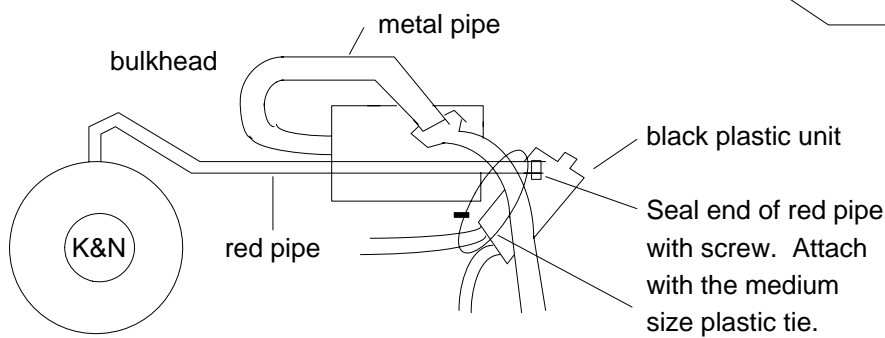

Drawing C

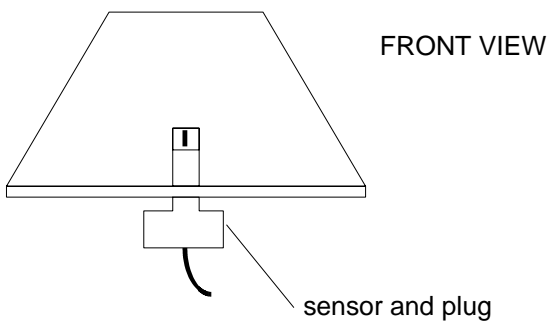

Drawing D

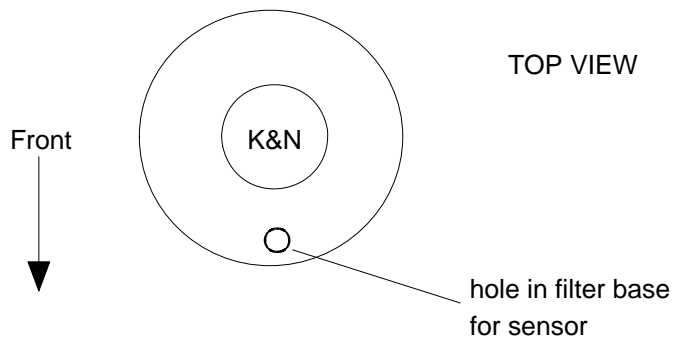

Drawing E

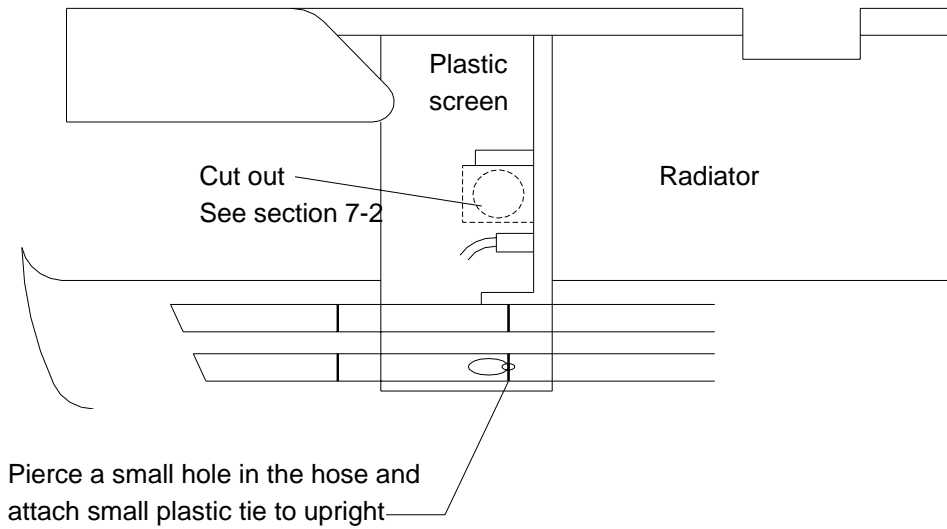

Drawing F

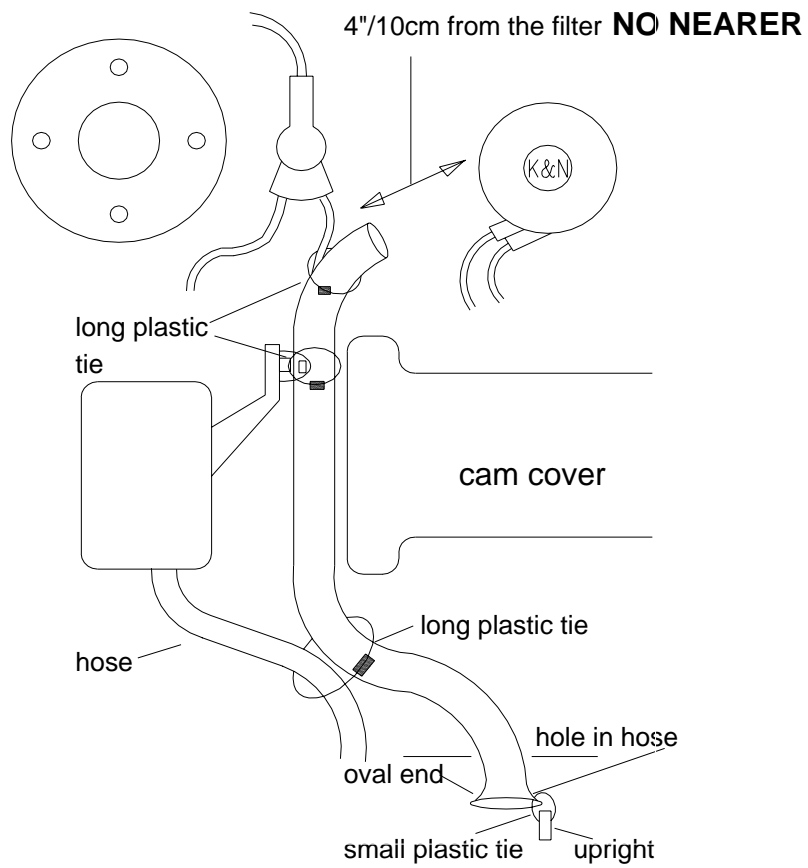

DRAWING G

Bonnet

