

PLEASE READ THE INSTRUCTIONS BEFORE FITTING THE KIT
If you have a problem, however small, call our Technical Department.
Tel:- 01925 636950. Fax:- 01925 243111. Mon - Thurs 8.30 - 5pm.

- 1 Remove the air filter assembly from the engine intake hose. The air intake pipe situated in the inner wing can be left in place.
- 2 Remove the mass air sensor, **MAS** from the air box.
- 3 Fit the new adapter to the **MAS** using screws, nuts and washers supplied and attach the support bracket to the **front** of the new adapter, using the M6 x 20mm screw, **Drawing A & B.**
- 4 Using the M6 x 40mm screw, washer and nut, attach the bracket to the front air box mounting, leaving in place the two rubber bushes, **Drawing B.**
- 5 Use the small plastic tie to keep the cables tidy, **Drawing B.**
- 6 Fit the filter to the new plastic adapter but don't overtighten the clip.
- 7 **Cold air system**
Raise the nearside of the car **taking the necessary safety precautions.** Using a shortened section of hacksaw blade, cut out the section shown in **Drawing C & D**, approx. 8cm x 8cm.
- 7.2 **Carefully** expand the hose to approx. 52" / 132cm. Feed the cold air hose up through the new cut out in the plastic inner wing. Feed under the battery to finish alongside the new bracket, **Drawing A & B.** Using a long plastic tie attach the hose to the hole in the bracket. Finish the hose 1" / 2.5cm past the bracket (**no more**) and position as **Drawing A.** Feed the other end of the hose over the metal stay and attach with a long plastic tie, **Drawing D.** Continue the hose to finish in the grille, **Drawing C & D**, and secure with a long plastic tie.
- 8 **Tuning. CAT. cars, no adjustments are required.**
Non CAT. cars, we suggest that a simple **CO2** test is carried out, as some cars may be set weaker than the standard setting. The **CO2** figure should not be set at more than **0.5%** above the recommended figure.
- 9 **Filter Maintenance**
Under normal conditions clean and reoil the filter at approx. 40000 miles / 65000 km. **Use only K&N cleaner** and oil and follow the instructions carefully.

K&N filters are pre oiled ready to fit.

The advantages of K&N's cold air intake system
Cooler air, being denser, will show positive improvements in power over filter systems that draw hot air from the engine bay.

This Kit Should Contain :-

- 1 x Air filter.
- 1 x Cold air hose assembly.
- 1 x Instruction sheet
- 1 x Instruction pack:-
 - 1 x Filter maintenance sheet.
 - 1 x K&N window sticker.
 - 1 x Million mile warranty card.
 - 1 x Leaflet.
- 1 x Fixing kit containing :-
 - 1 x M6 x 40mm hex head screw.
 - 1 x M6 x 20mm hex head screw.
 - 3 x M6 x 16mm hex head screws.
 - 5 x 6mm spring washers.
 - 5 x M6 hex nuts.
 - 1 x Metal washer.
 - 1 x Plastic cable tie (8" long).
 - 3 x Plastic cable ties (14" long).
 - 1 x #48 Hose clip.
 - 1 x Bracket.
 - 1 x Plastic adaptor.

**IMPORTANT INSTRUCTIONS
FOR ROUND ENTRY
CLAMP ON AIR FILTERS**

Gently tighten the hose clip to the point where the filter will just rotate on the pipe or intake flange. Reposition the K&N logo straight, then **give the clip two turns i.e. 360 , no more.**

FITTING YOUR OWN 57i KIT

If not, **it is essential** that the person fitting the kit (e.g. mechanic) **carefully follows these particular instructions** even if he has fitted K&N kits before. This will save you both time and money. Kits incorrectly fitted may show a loss in performance e.g. the positioning of the essential cold air hose, (flexi expandable and rubber hoses are used).

A final check under the bonnet, by yourself, with the instructions, would seem sensible.

Drawing A

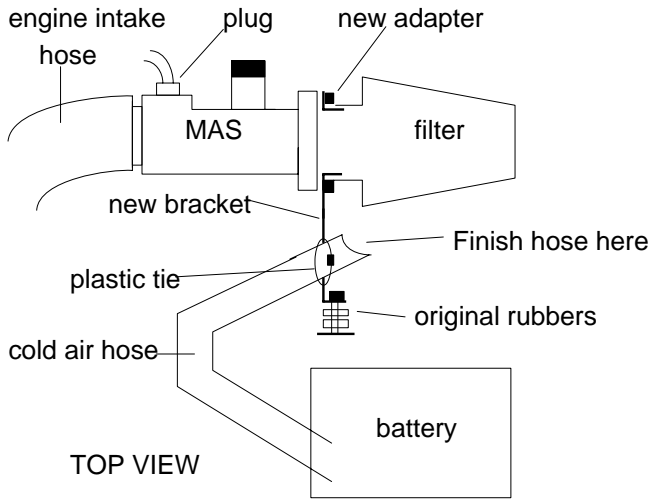

Drawing B

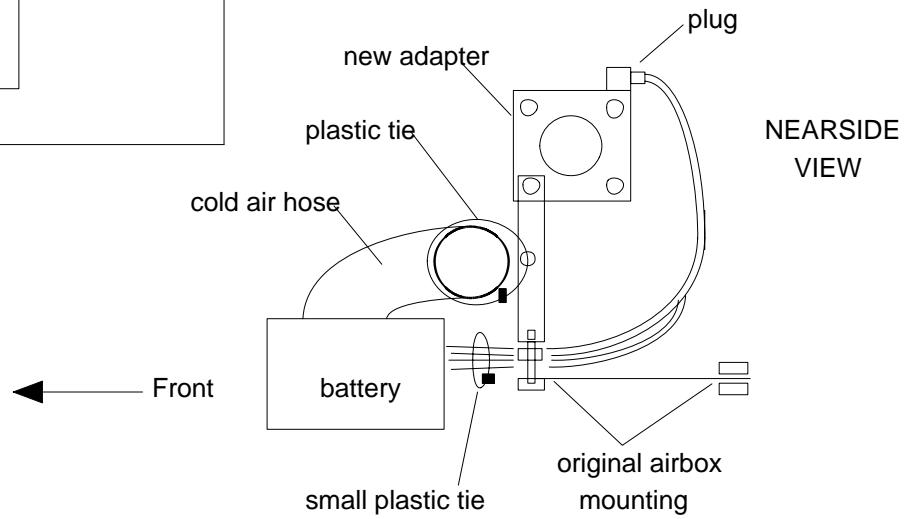

Drawing C

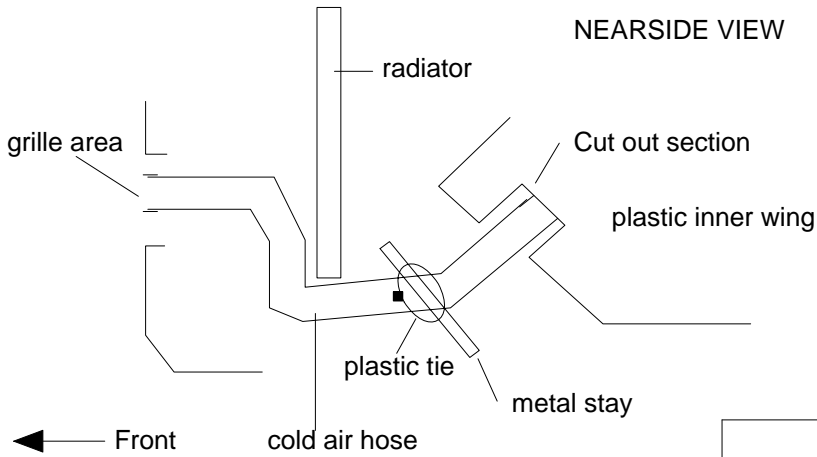

Drawing D

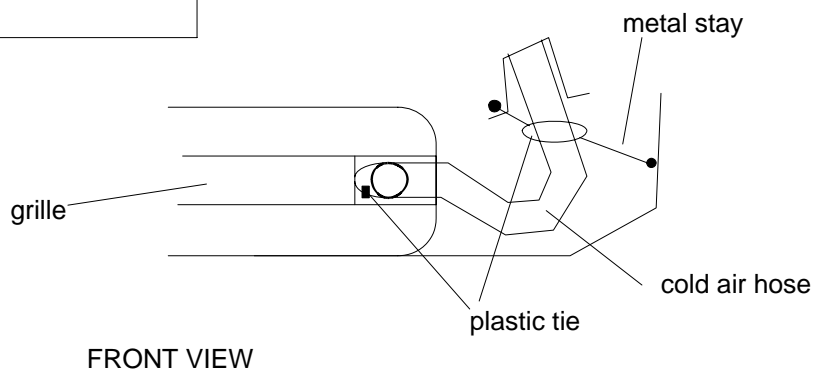

FRONT VIEW